

## Transformer-Isolated Gate Driver Provides very large duty cycle ratios

(HEXFET® is the trademark for International Rectifier Power MOSFETs)

Transformer coupling of low level signals to power switches offers several advantages such as impedance matching. DC isolation and either step up or step down capability. They also provide negative gate bias to reduce the risk of “dv/dt induced turn-on”.

Unfortunately, transformers can deliver only AC signals since the core flux must be reset each half cycle. This “constant volt seconds” property of transformers results in large voltage swings if a narrow reset pulse, i.e., a large duty cycle is required (Figure 1).

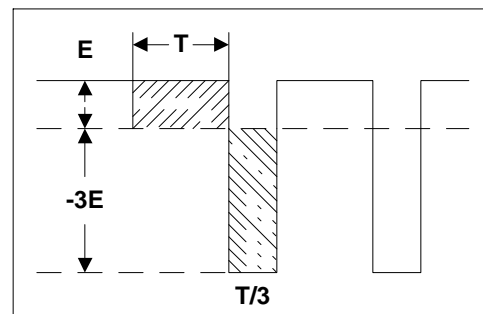

**Figure 1.** Constant-Volt-Seconds Characteristics of Transformers

**NOTE: VOLT-SECONDS PRODUCT IN SHADED AREAS MUST BE EQUAL. THIS CAUSES RESET VOLTAGE TO BE 3 TIMES APPLIED VOLTAGE E.**

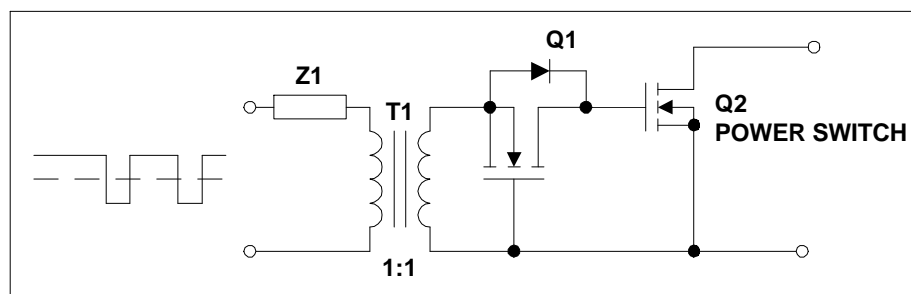

**Figure 2.** Wide Duty Cycle HEXFET Power MOSFET Driver circuit

For this reason transformers in semiconductor drive circuits are limited to 50% duty cycle or roughly equal pulse widths positive and negative because of drive voltage limitations of the semiconductors themselves. For large duty cycle ratios designers must choose an alternative to the transformer, such as an optical coupler to provide the necessary drive isolation.

Optoisolators for power electronics require high dV/dt capability and are expensive. They also require additional floating power sources which add complexity and cost. Most of them require a buffer stage to handle the large gate capacitances, typical of power devices. If duty cycles are such that optoisolators are the only alternative, they can be used in a more cost-effective way as drivers for a MOS-gate driver.

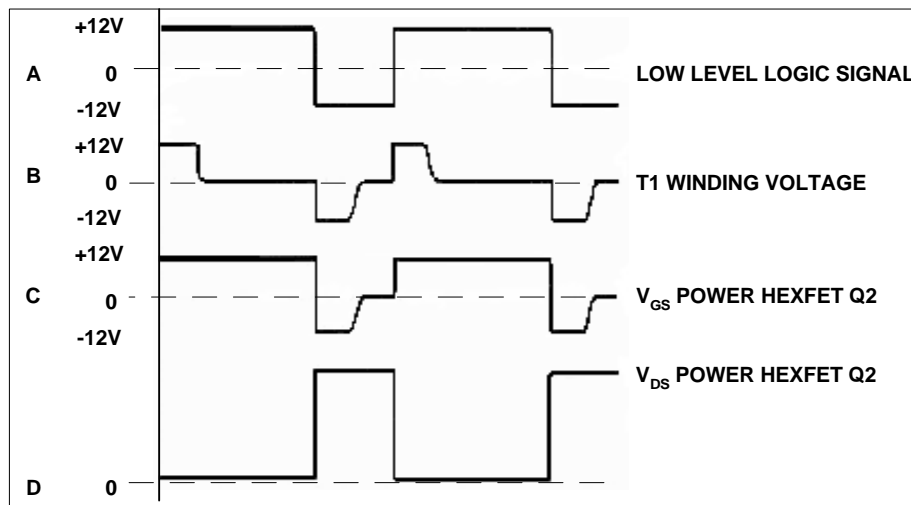

**Figure 3.** Waveform Characteristics of HEXFET POWER MOSFET Driver Circuit

The circuit in Figure 2 provides a low impedance turn-on drive, and minimum pulse widths (on or off) of approximately 1 microsecond; furthermore, it can have any desired voltage ratio, and provides electrical isolation. In Figure 2, Q2 is the main power device, shown as a MOSFET, providing the switching function for a switching power supply, motor drive or other application requiring isolation between the low level logic and high power output. Q1 is a low power HEXFET Power MOSFET such as the IRLML2803, which is used to control the drive signals to Q2, and T1 is a small 1:1 driver transformer providing electrical isolation from, and coupling to, the low level circuitry.

The waveforms in Figure 3 explain the circuit operation. Waveform A is the desired logic signal to be switched by Q2. When this voltage is applied to the primary of T1 the waveform is supported by changing core flux until saturation occurs as shown in waveform B. At this time the winding voltages fall to zero and remain so until the core flux is reversed by the negative-going portion of waveform A saturation will again occur if the negative-applied pulse exceeds the volt-seconds capability of the core.

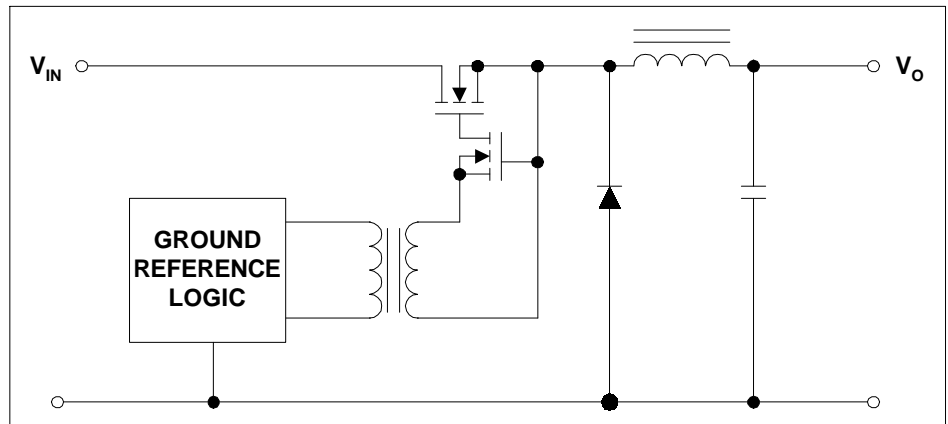

Figure 4. Single Switch Regulators

During the positive portion of the secondary waveform, which, of course, has the same form as the primary, the intrinsic diode of Q1 is in forward conduction and Q2 receives a positive gate drive voltage with a source impedance of Z1 plus the intrinsic diode forward impedance.

In a practical circuit this can be less than 10 Ohms total, with a consequent turn-on time of around 75nsec.

When T1 saturates, the intrinsic diode of Q1 isolates the collapse of voltage at the winding from the gate of the power device and the input capacitance  $C_{iss}$  of the power switch holds the gate bias at the fully enhanced condition for a time limited only by the gate leakage current of Q2 as indicated in Figure 3c.

When waveform A goes 12 volts negative Q1 will become fully enhanced; and the main switch Q2 will now be turned off at approximately -12V at a source impedance  $Z1 + R_{DS(ON)}$  of Q2.

This will again be less than 10 Ohms and will yield a turn-off time less than 100nsec.

When T1 again saturates, during the negative half cycle, its winding voltages fall to zero and Q1 turns off. As T1 voltage collapses, the gate of Q2 also follows this voltage and remains at zero bias.

The drain voltage of the power HEXFET Power MOSFET Q2 appears in Figure 3d, showing that it is indeed a mirror image of waveform A, the desired low level logic signal.

Note that because T1 need only support a 12V signal, for 1msec or less, it is very small—and inexpensive. In a practical circuit Z1 is frequently a 0.1 mF capacitor, and the signal source is a low impedance driver such as a PWM controller or gate driver.

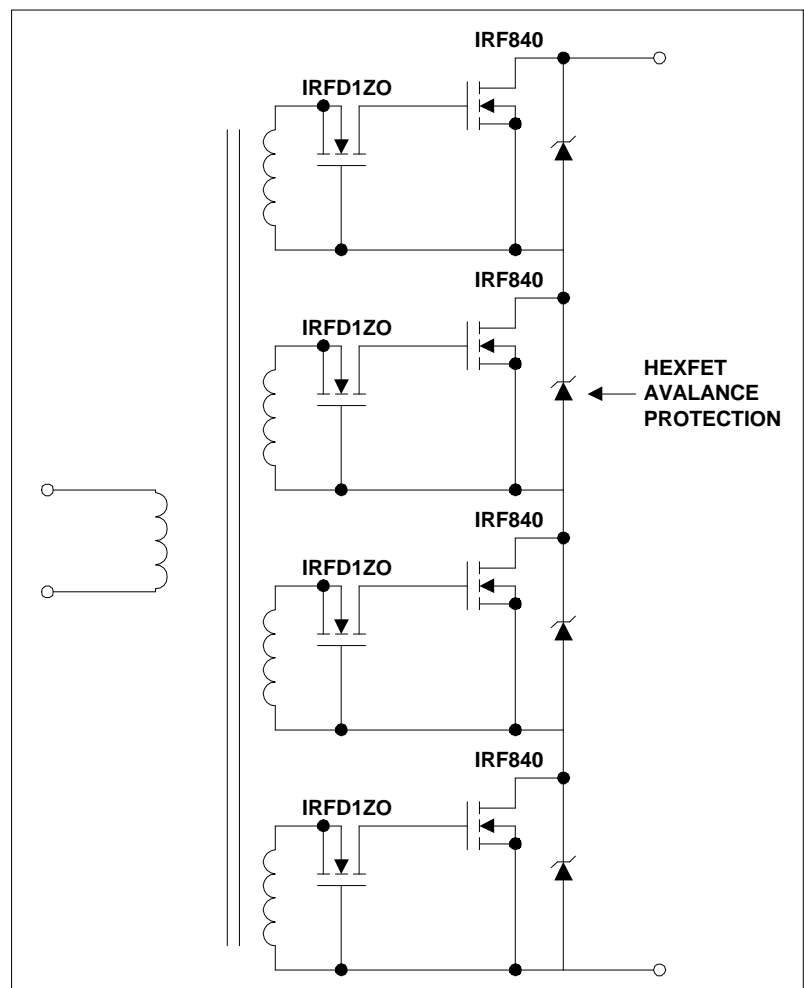

Figure 5. High Voltage, High Power HEXFET Power MOSFET Switch (500V, 8A per Section)

It should be noted that the circuit in Figure 3(b) may not provide the necessary noise immunity when the power device is off. The gate-source voltage of Q2 in the OFF state returns to zero when T1 saturates and the only noise immunity is provided by the threshold voltage of Q2 ( $2V < V_{TH} < 4V$ ). In most applications it may be desirable to provide more noise immunity, by adding another small N-Channel HEXFET Power MOSFET (typically another IRLML2803) as shown in Figure 7.

The circuit now provides -12V to the power MOSFET *after the transformer saturates*, and this reverse bias remains until the next positive half cycle of drive. Thus, a minimum of 14V noise immunity is provided which should be adequate for all applications. The cost and noise immunity of this solution is much less than alternatives using optoisolators and their auxiliary supplies.

Figures 5 and 6 show two applications where this gate drive method is particularly advantageous. The first is a high-voltage, high-frequency switch. The second is a bi-directional ac switch.

### Transformer T<sub>1</sub> Considerations

In the circuits illustrated, the transformers were built from miniature tape wound or ferrite toroids. Typical part numbers for these cores are as follows:

- (1) Tape Wound Cores  
Magnetics Inc. #80558-(1/2D)MA  
#52402-ID
- (2) Ferrite Toroids  
Ferroxcube #266CT 125-3E2A or equivalent

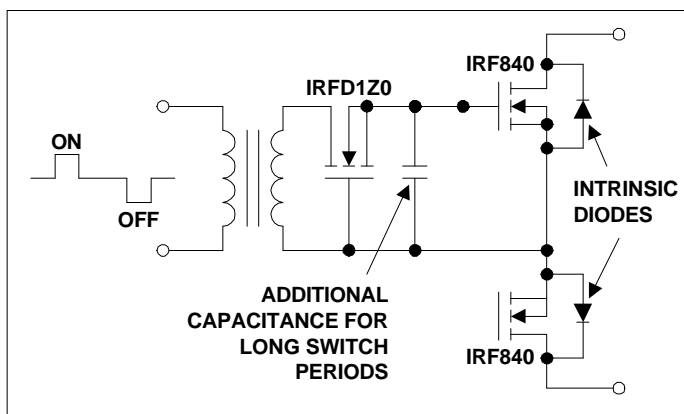

**Figure 6.** Bi-directional AC Switch using HEXFET POWER

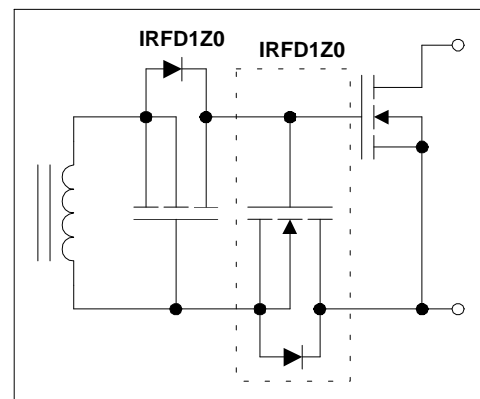

**Figure 7.** Driver Circuit with additional Noise Immunity

Choice of a core type is not critical provided that 10 to 20 turns bifilar of suitable wire can be hand-wound onto it.

The size of core should be chosen so that adequate insulation thickness can be used for the isolation voltage requirements and to reduce interwinding capacitance.

Square Permalloy 80 cores are more expensive than ferrite types, but they have much narrower hysteresis loops and hence need fewer ampere turns of excitation. This can make a critical difference when the driver has limited current capability.

Bifilar windings improve the magnetic coupling of primary to secondary, and it is also important to space the turns to occupy 360° of the core circumference to minimize leakage inductance. Unity turn ratios between primary and secondary also serve to minimize leakage inductance and hence optimize the transformer coupling coefficient.

### Related Topics:

*MOS-gate drivers*  
*Negative gate bias*

## Gate drive buffers

International  
**IOR** Rectifier

**WORLD HEADQUARTERS:** 233 Kansas St., El Segundo California 90245, Tel: (310) 322 3331

**EUROPEAN HEADQUARTERS:** Hurst Green, Oxted, Surrey RH8 9BB, UK Tel: ++ 44 1883 732020

**IR CANADA:** 7321 Victoria Park Ave., Suite 201, Markham, Ontario L3R 2Z8, Tel: (905) 475 1897

**IR GERMANY:** Saalburgstrasse 157, 61350 Bad Homburg Tel: ++ 49 6172 96590

**IR ITALY:** Via Liguria 49, 10071 Borgaro, Torino Tel: ++39 11 451 0111

**IR FAR EAST:** K&H Bldg., 2F, 3-30-4 Nishi-Ikeburo 3-Chrome, Toshima-Ki, Tokyo Japan 171 Tel: 81 3 3983 0086

**IR SOUTHEAST ASIA:** 315 Outram Road, #10-02 Tan Boon Liat Building, Singapore 0316 Tel: 65 221 8371

Data and specification subject to change without notice.